

Umecc[®]

Your reliable gateway to low cost and high quality metallurgical equipment from China

UMECC provides a wide range of high quality products to the steel industry from a large group of first class manufacturers in China who operate a variety of manufacturing facilities, focus on specific product lines, and are leaders in their fields. Our offerings include all major equipment, spare parts, and refractories for the entire iron and steel production process, from mining to rolling, for the lowest cost and at the highest standard. We are the local extension of the UMECC Manufacturer Group in China, allowing our customers to benefit from our cost advantage and high-quality on-site service.

UMECC products are widely used at many world renowned companies in the industry.



Seamlessly bringing the global marketplace to your local business

We are intimately familiar with the intricacies of Chinese manufacturing and understand the particulars of our customers' needs and what is behind their drawings and specifications. Different technical standards and understandings, conflicting expectations, and linguistic and cultural differences between the

customer and the manufacturer are expertly resolved by UMECC based on a comprehensive technical assessment and detailed quality program. We are the dependable, technical, and logistical bridge between our customers and our manufacturers. By serving our customers and our manufacturers in this way, we can provide unparalleled value to both.



Slag Pots

Cutting Edge Analysis and Design

REM Treated Anti Bulging Steel

Low Carbon and Low S/P BOF Steel
for Crack Sensitive Applications

Dual Heat Treatment

Effective Field Solutions

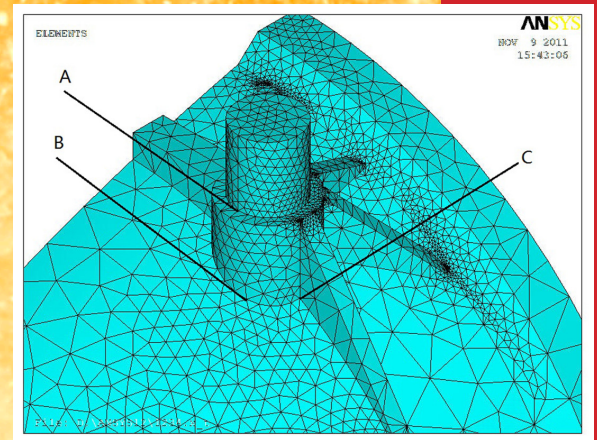
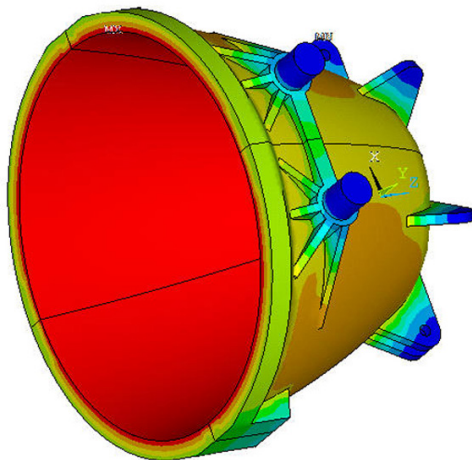
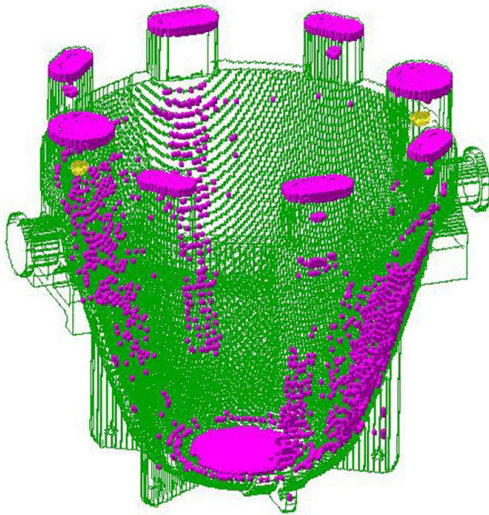

Uncompromising pursuit of quality and customer satisfaction



Working with UMECC means you are utilizing a team of highly dedicated engineers, technicians, logistics and order fulfillment experts who work hand in hand with some of the best manufacturers and engineering firms in China.

UMECC Manufacturer Group members have a wealth of experience working together with world renowned engineering firms for projects at both, steel mills in China and abroad, and they are familiar with and adhere to international standards like DIN, ASME, JIS and GB.

UMECC offers engineering support for all products it supplies, including detailed design, drawing conversions, equipment adaption and enhancement. In-house engineering capabilities are a vital part of UMECC's services, allowing us to guarantee an efficient and flawless transition of engineering services from our manufacturers in China to our customers, anywhere in the world.

Our comprehensive Quality Assurance Program results in consistent quality and adherence to the highest standards

In addition to a 100% product inspection before ex works delivery, the program covers manufacturer qualification and selection, application studies, review, interpretation and clarification of customer drawings and specifications, issuing of detailed quality programs for our manufacturing group members in the Chinese language, tracking and documentation of production progress, and adherence of standards.

UMECC Manufacturer Group members, regardless of how big or small, are all ISO certified and subject to continuous examination under the UMECC Vendor Qualification System.



References



Umecc[®] Locations



Please call or write to us for more specific information and detailed references or visit our website, www.umecc.com.



+1 (888) 966-6322
+1 (513) 336-9744



mail@umecc.com
Fax: +1 (513) 336-6185



9468 Meridian Way
West Chester, OH 45069